

# A10

## Quick Installation User Guide

## Packaging list

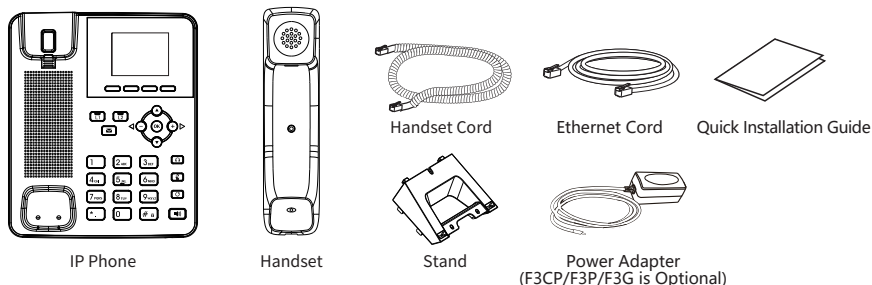

## Screen icon

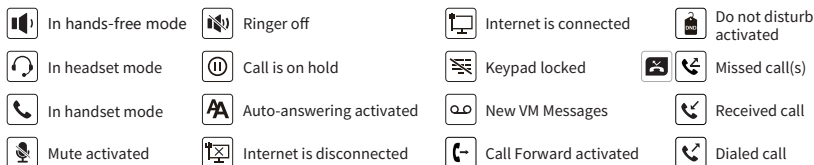

## Keys features



Soft keys



Message waiting indicator



Left and right navigation keys  
 In idle mode or during ringing:  
 increase or decrease ringer volume  
 In communication: increase or decrease earpiece, headset or hands-free volume  
 Up navigation key, Shortcut to call log  
 Down navigation key, Shortcut to Status  
 OK key, Shortcut to Menu



Line keys



Voice key, Access to voicemail



Headset key, Activate/deactivate Headset



In idle mode: ringer off  
 In communication mode:  
 mute/un-mute a call



Redial key, Access to redial the last record



Hands-free key, Activate/deactivate hands free



Long press to lock keypad.  
 Enter PIN to unlock keypad (default 123)

## Installation the device

### Bracket desktop installation

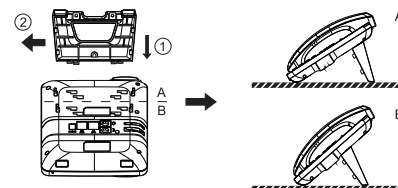

### Bracket wall mounting

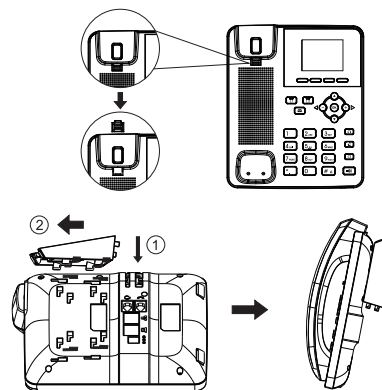

### Connecting to the Device

Please connect power adapter, network, PC, headset, and headset to the corresponding ports as described in below picture.

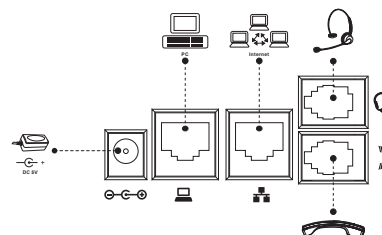

## Configuration

### Configuration via Phone

1. Press Menu > 3 Setting > 2 Advanced Settings(Default password 123)
2. Select Network: To configure the Network Settings (DHCP/Static/PPPoE)
3. Select Accounts: To configure enable the account, fill the SIP server address, port, user name, password etc.

### Configuration via Web

1. Get the IP address from the phone: Press key, or Menu > 1 Status > 2 IP.
2. Login: Input the IP address in the web browser. The PC and phone should be in the same IP address segment(The default username and password are both 'admin' .)
3. Configure: Select network/Account etc, and fill the relevant content.

## Language setting

1. Press Menu key > 3 Settings > 1 Basic Settings > 7 Language.
2. Select the desired language and press Save soft key.

## Making a call

1. **Pre-dialing:** enter the phone number and pick up the handset.
2. **Direct dialing:** lift the handset and enter the phone number.
3. **Handsfree:** enter phone number and press or vice versa.
4. **Headset:** enter phone number and press or vice versa.
5. **Designated line:** press line key, enter phone number and press dial key.

## Accepting a call

1. **With the handset:** pick up the handset.
2. **With a headset:** press .
3. **With the handsfree:** press .

## Putting a call on hold

1. Press Hold soft key, caller is put on hold.
2. To retrieve the call press Resume soft key.  
**Note:** with more than one active call, select desired call with the navigator keys and use the corresponding soft key to hold or resume.

## 3-party conference

1. Once in line with 1st caller, press Conf soft key, 1st caller is put on hold.
2. Then call the 2nd number.
3. After, 2nd call is established, press Conf soft key to set up the conference.

## Call transfer

### Attended transfer:

1. Press XFER soft key during the active conversation, the call is put on hold.
2. Dial the second telephone number.
3. When the call is answered, then press XFER soft key to complete the operation.



### Blind transfer:

1. Press XFER soft key during the active conversation, the call will be on hold.
2. Then enter the 2nd telephone number and press XFER soft key.





## Call forward

1. Press Menu > 2 Features > 1 Call Forward.
2. Select the line, the type of forward, enter the destination number and status and Save.

## Call Mute



1. Press  to Mute the microphone during the call.
2. Press  again to un-mute the conversation.

## Call list

1. Press  key or Menu > 6 Call Logs > 1 Local Ca
2. Scroll through the list using 
3. To dial an entry, press Dial soft key or pickup handset or press  or .

## Phonebook

### Access phonebook:

1. Press Dir soft key.
2. Select Contacts.
3. To dial an entry, press Dial soft key or pickup handset or press  or .



### Add new entry:

1. Press Dir soft key > 1 Contacts > Press Add.
2. Enter name and number and press Save soft key.

## Programmable keys

1. You can also configure shortcuts for the navigation keys, and which will be available in idle mode.
2. Press Menu > 3 Settings > 1 Basic Settings > 1 Keyboard, select among the configurable items, and select your desired type and value, press OK or Save soft key.

## Redial

1. Press , select the desired call and press Dial soft key or pickup handset or press  or .

## Do not disturb

1. Press DND soft key, or Menu > 2 Features > 5 DND.
2. Select the Mode and Type, and press Save soft key.

## Voice mail

1. To access your voice mailbox, press  or Menu > 4 Applications > 3 Voice Message, number of messages will be indicated if provided by your server or pbx.
2. Select the line and press Dial to call.

## Contact

T: 0333 366 0770  
E: info@excel-comms.co.uk